

Charlotte Street, W1T 4QE

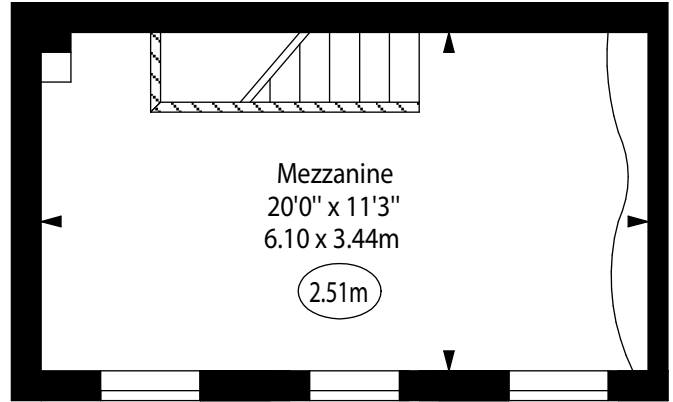

○ - Ceiling Height

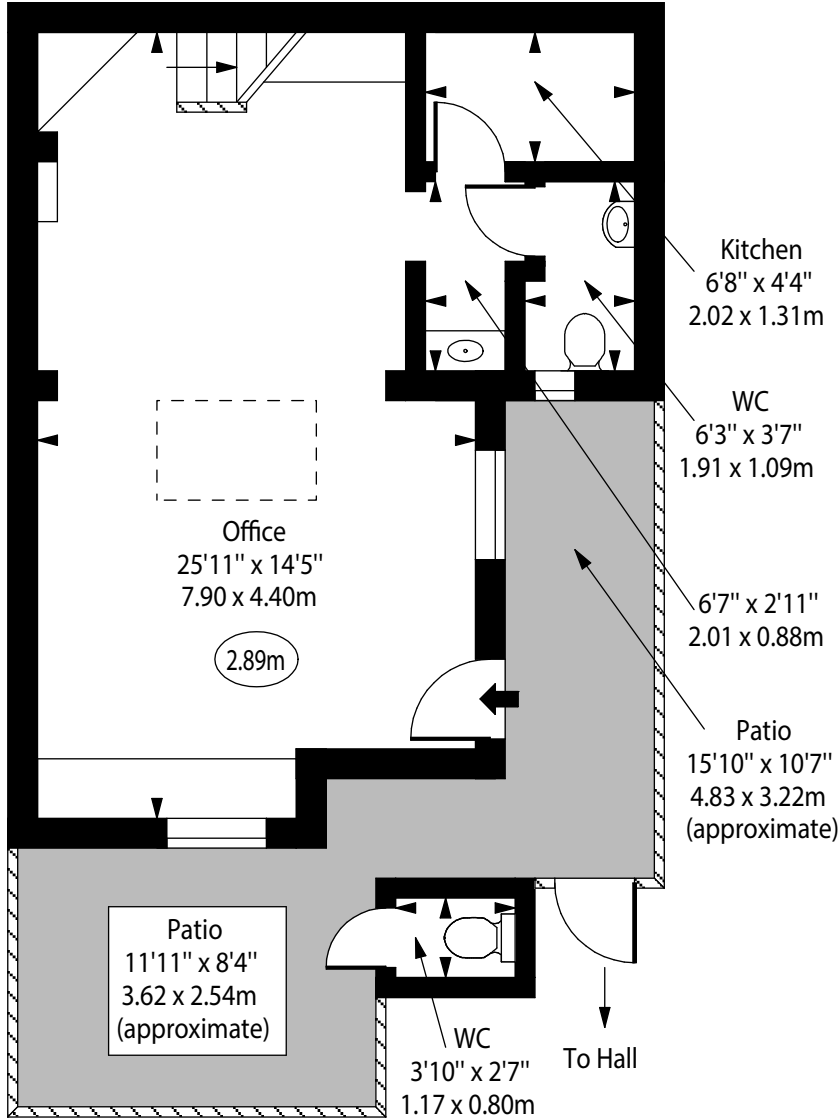

Mezzanine

Gross Internal Area - 225 Sq Ft - 20.90 Sq M
 Net Internal Area - 206 Sq Ft - 19.13 Sq M

Ground Floor

Gross Internal Area - 420 Sq Ft - 39.01 Sq M
 Net Internal Area - 332 Sq Ft - 30.84 Sq M

Gross Internal Area 645 Sq Ft - 59.92 Sq M

Net Internal Area 538 Sq Ft - 49.98 Sq M

(Excluding WC & Kitchen)

Bathrooms & Kitchen Area 78 Sq Ft - 7.24 Sq M

For Illustration Purposes Only - Not To Scale

www.goldlens.co.uk

Ref. No. 019279R